



System 100 - Chemical resistant (PP)

Extraction arms

Table mounting	100 PP 2
Wall/Ceiling mounting	100 PP 3

Hoods

Metal hood 1-10024-7-5	100 PP 4
Round hood 1- 10035-7-5	100 PP 5
Round hood 1-10050-7-5	100 PP 6
Flat hood 1-1004228-7-5	100 PP 87

Brackets

U-profile 30-100-5	100 PP 8
Wall bracket 2-100-203	100 PP 9
Wall bracket 2-100-203-22	100 PP 10
Ceiling columns	100 PP 11

Other accessories

Reducer 4-100125	100 PP 12
Cover flange 4-250-250	100 PP 13
Support bracket 2-100-5	100 PP 14
Protective netting 5-18	100 PP 15



System 100 – Chemical resistant (PP)

All components RoHS-compatible.

Design:

- Extraction arm for mounting on table
- Working range 795 - 2130 mm
- Recommended airflow 140 to 400 m³/h
- Diameter of tube Ø100 mm
- POP[®] rivets made of acid-proof stainless steel (AISI 316L) for increased durability in aggressive environments
- Tubes and joints made of chemical resistant polypropylene (PP)
- Colour of joints: white
- All O-rings maintenance free
- Integrated valve. When in an open position out of the flow path to maintain the maximum amount of flow
- All threaded stays, springs and thumbscrews made of acid-proof stainless steel (AISI 316L)
- All hoods can be provided with a protective netting (accessory) to reduce the risk of extracting foreign objects
- Dismantling of the arm without tools for cleaning



Links: [Pressure drop chart](#), [Mounting without gas spring](#), [Mounting with gas springs](#), [User's manual](#)
[Capture efficiency](#), [Material compatibility](#)

Working area

We do not recommend a stationary working position in the upper or lower working area.

All units in mm

* With 1 gas spring

** With 2 gas springs

A: Model 100-55-1-7-5
B: Model 100-4540-1-7-5
C: Model 100-5545-1-7-5
D: Model 100-6555-1-7-5
E: Model 100-9065-1-7-5*
F: Model 100-10585-1-7-5**

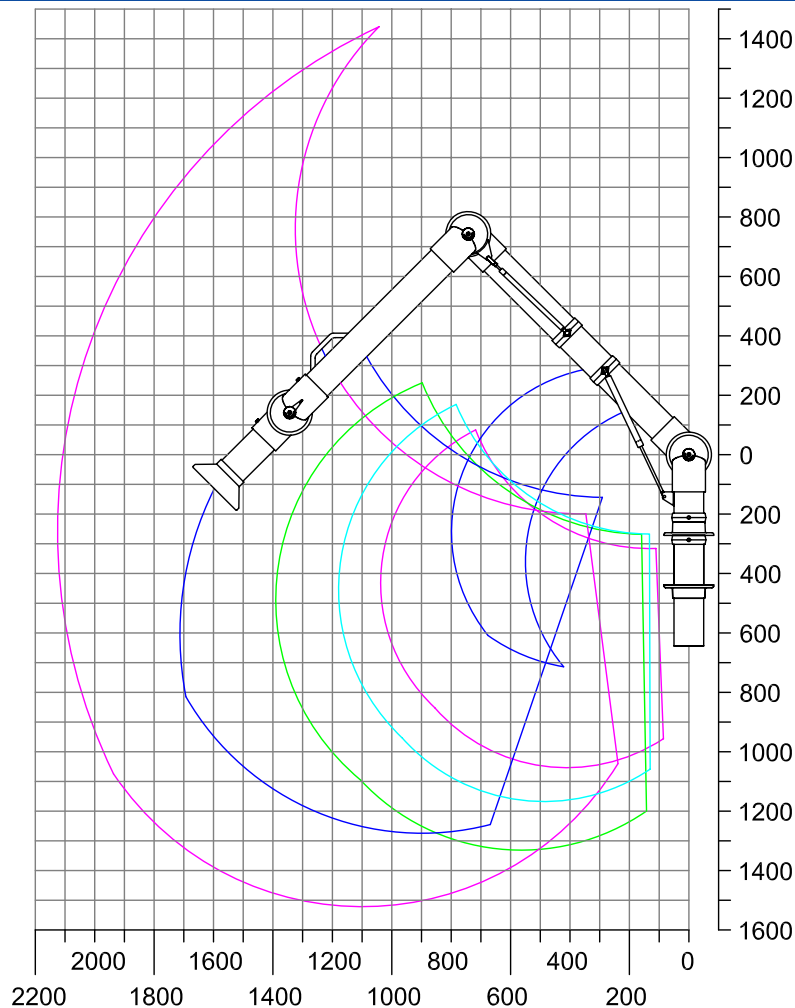



System 100 – Chemical resistant (PP)

All components RoHS-compatible.

Design:

- Extraction arm for mounting on wall and ceiling
- Working range 795 - 2630 mm
- Recommended airflow 140 to 400 m³/h
- Diameter of tube Ø100 mm
- POP® rivets made of acid-proof stainless steel (AISI 316L) for increased durability in aggressive environments
- Tubes and joints made of chemical resistant polypropylene (PP)
- Colour of joints: white
- All O-rings maintenance free
- Integrated valve. When in an open position out of the flow path to maintain the maximum amount of flow
- All threaded stays, springs and thumbscrews made of acid-proof stainless steel (AISI 316L)
- All hoods can be provided with a protective netting (accessory) to reduce the risk of extracting foreign objects
- Dismantling of the arm without tools for cleaning



Links: [Pressure drop chart](#), [Mounting without gas spring](#), [Mounting with gas springs](#), [User's manual](#)

[Capture efficiency](#), [Material compatibility](#)

Working area

We do not recommend a stationary working position in the upper or lower working area.

All units in mm

* With 1 gas spring

** With 2 gas springs

- A: Model 100-55-3-7-5
- B: Model 100-4540-3-7-5
- C: Model 100-5545-3-7-5
- D: Model 100-6555-3-7-5
- E: Model 100-9065-3-7-5*
- F: Model 100-10585-3-7-5**
- G: Model 100-135105-3-7-5**

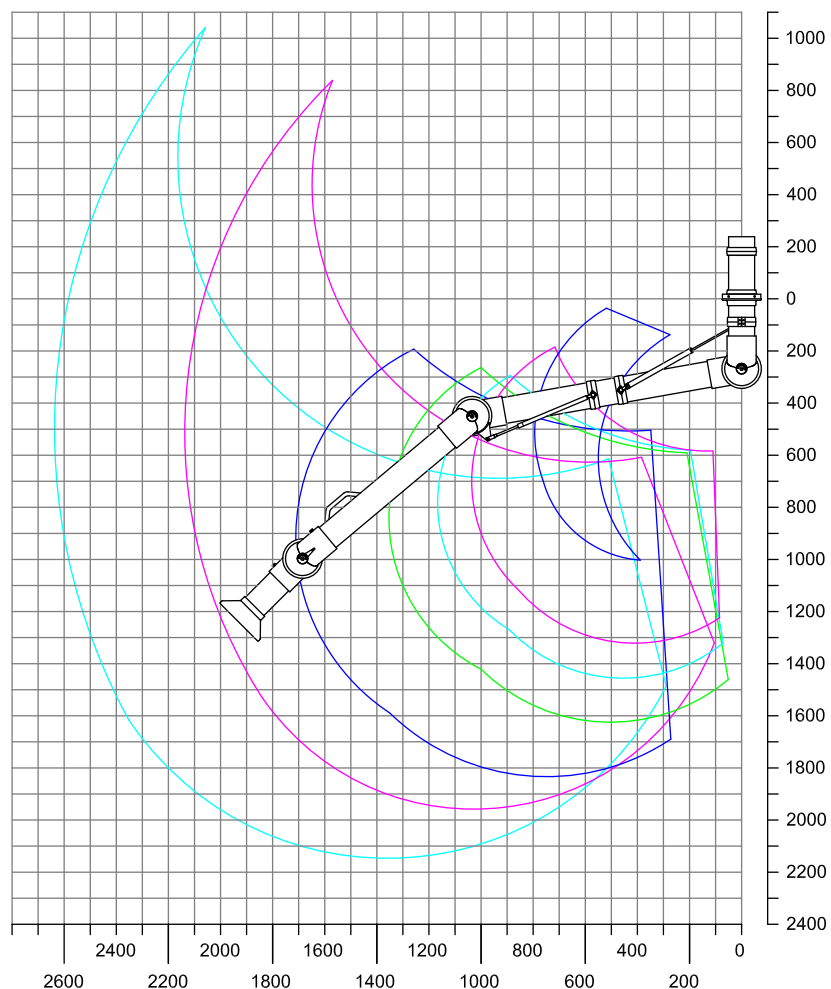



System 100 – Chemical resistant (PP)

- Metal hood recommended when extracting hot gases, fumes, light dust concentrations etc.
- Diameter of the hood: $\text{Ø}200$ mm
- Hood made of polyester powder-coated aluminium
- Connection tube made of chemical resistant polypropylene (PP)



Capture efficiency

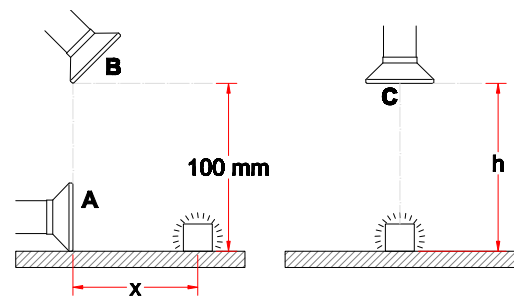
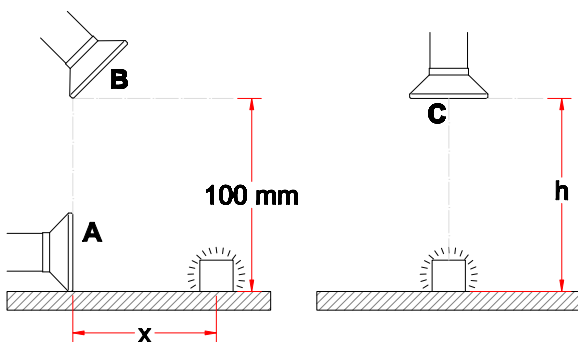

Drawing

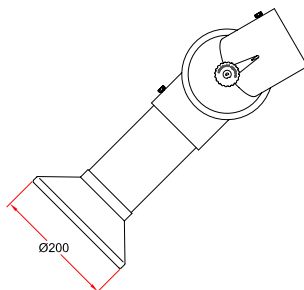



System 100 – Chemical resistant (PP)

- Round hood recommended for light fumes, gases and over open vessels
- Diameter of hood: Ø385 mm
- Increased efficiency at an angled position
- Hood and connection tube made of shatterproof, chemical resistant polypropylene (PP)
- Colour of flange: white



Capture efficiency

Measurements for this product are comparable with article no. [1-10050](#).

Drawing

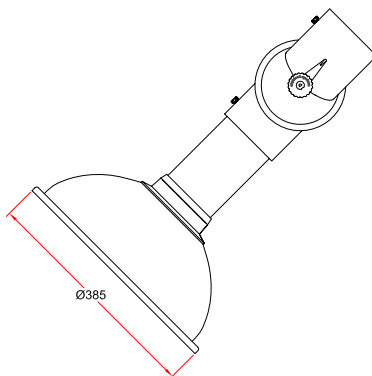



System 100 – Chemical resistant (PP)

- Round hood recommended for light fumes, gases and over open vessels
- Diameter of the hood: Ø500 mm
- Increased stability when moving the hood due to reinforced rim of the hood
- Increased efficiency at an angled position
- Hood made of chemical resistant polypropylene (PP)
- Flange and connection tube made of chemical resistant polypropylene (PP)
- Colour: white



Capture efficiency

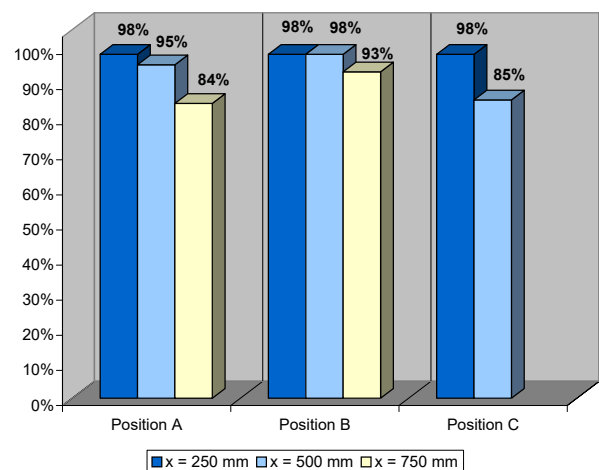
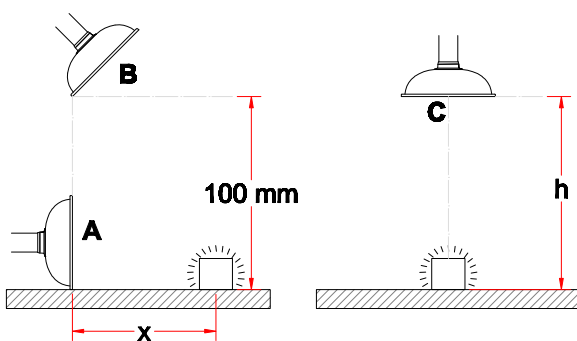

Drawing

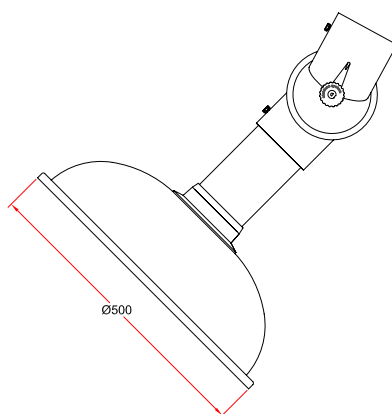



System 100 – Chemical resistant (PP)

- Flat hood recommended when extracting heavy gases and fumes
- Dimensions of the hood: 420x280 mm
- Increased efficiency when placed vertically on a surface
- Hood, flange and connection tube made of chemical resistant polypropylene (PP)
- Colour: white



Capture efficiency

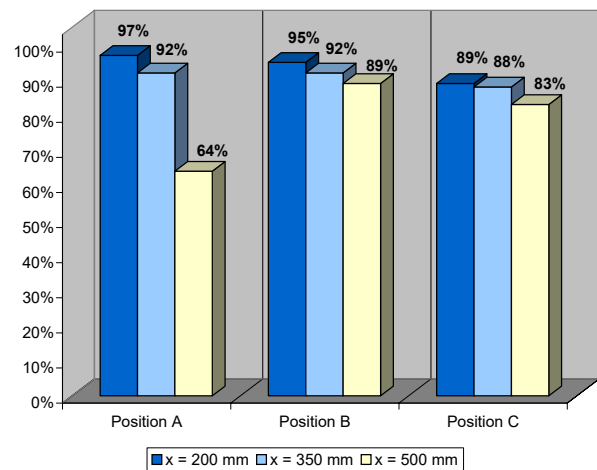
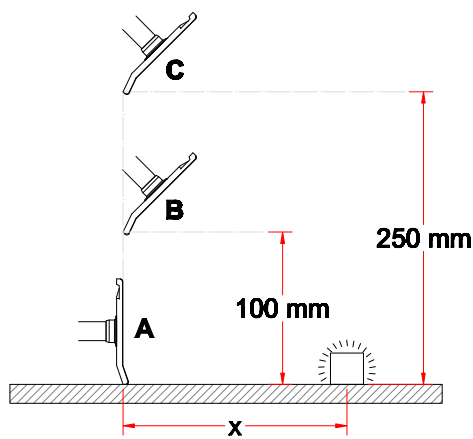

Drawing

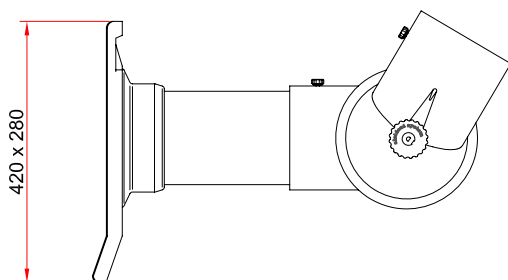



System 100 – Chemical resistant (PP)

- Bracket/U-profile to support the socket pipe of long extraction arms for table mounting
- Made of steel with a polyester powder-coating on all surfaces
- Colour: white

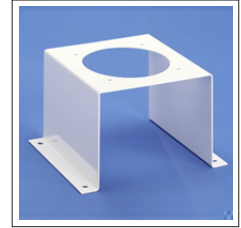

Drawing

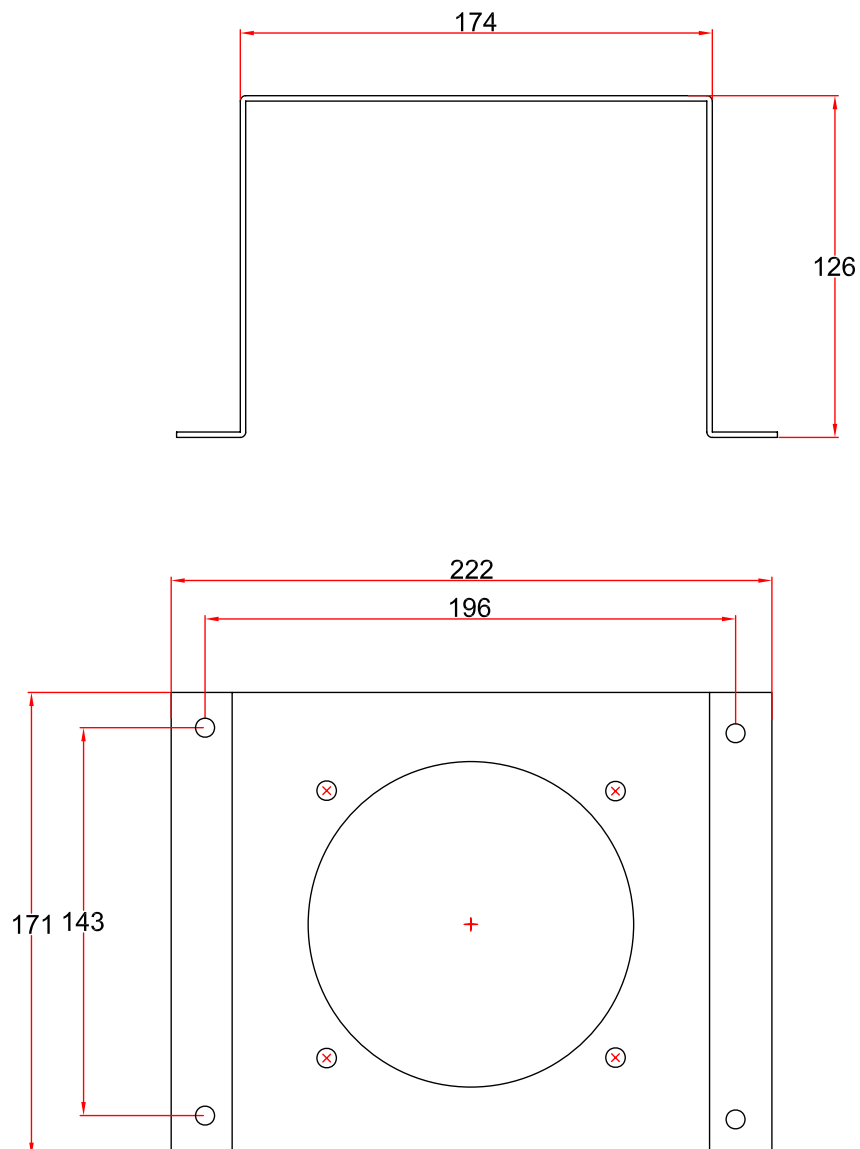

Wall bracket 2-100-203



System 100 – Chemical resistant (PP)

- Wall bracket to mount extraction arms for wall or ceiling mounting to the wall
- Made of steel with a polyester powder-coating on all surfaces
- Colour: white
- Reducer to duct Ø125mm included



Drawing

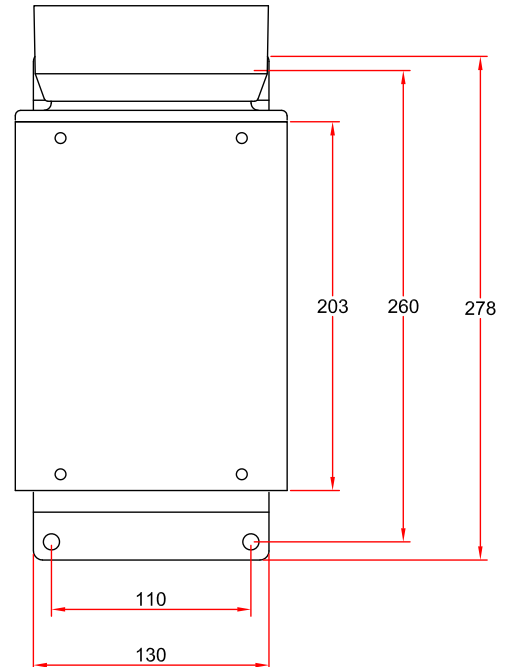
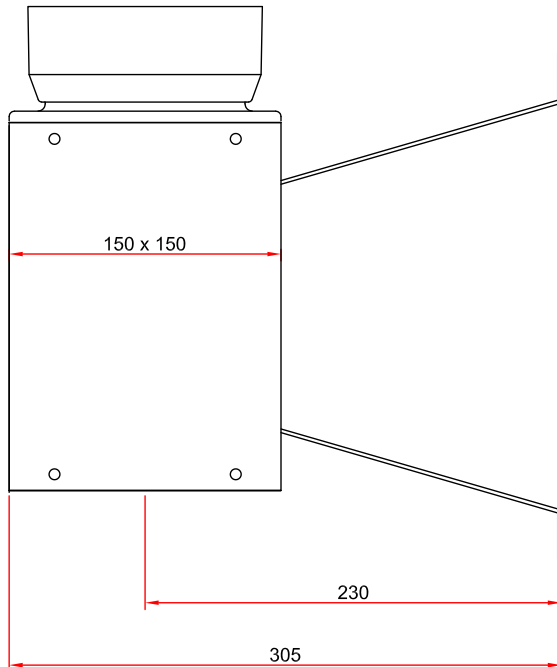



System 100 – Chemical resistant (PP)

- Wall bracket to mount extraction arms for wall or ceiling mounting to the wall
- Made of acid proof stainless steel (AISI 316L)
- Colour: white
- Reducer to duct Ø125mm included



Drawing

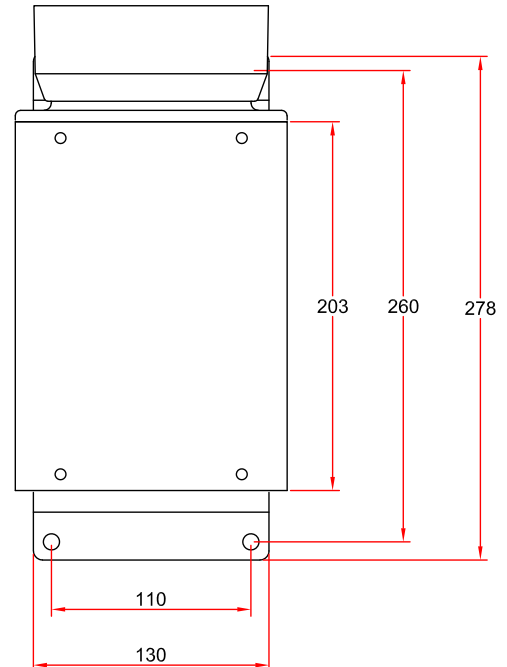
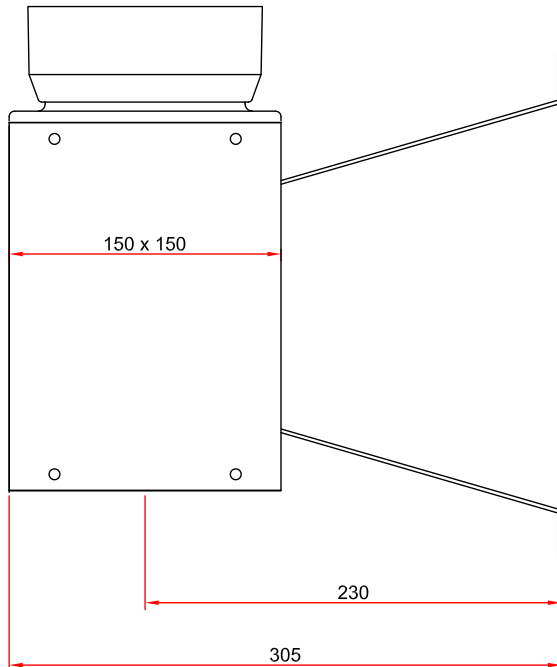



System 100 – Chemical resistant (PP)

- Ceiling column to mount extraction arms for ceiling mounting to the ceiling
- Strong construction made of steel
- Increased durability due to polyester powder-coating on all surfaces
- Top connection (-20) or side connection Ø125 (-80)
- Colour: white (-) or black (-050)
- Dimension: 150x150 mm
- Length: 500-2500 mm

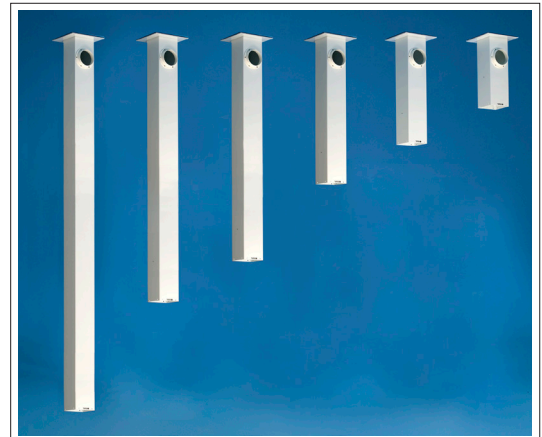

Drawing

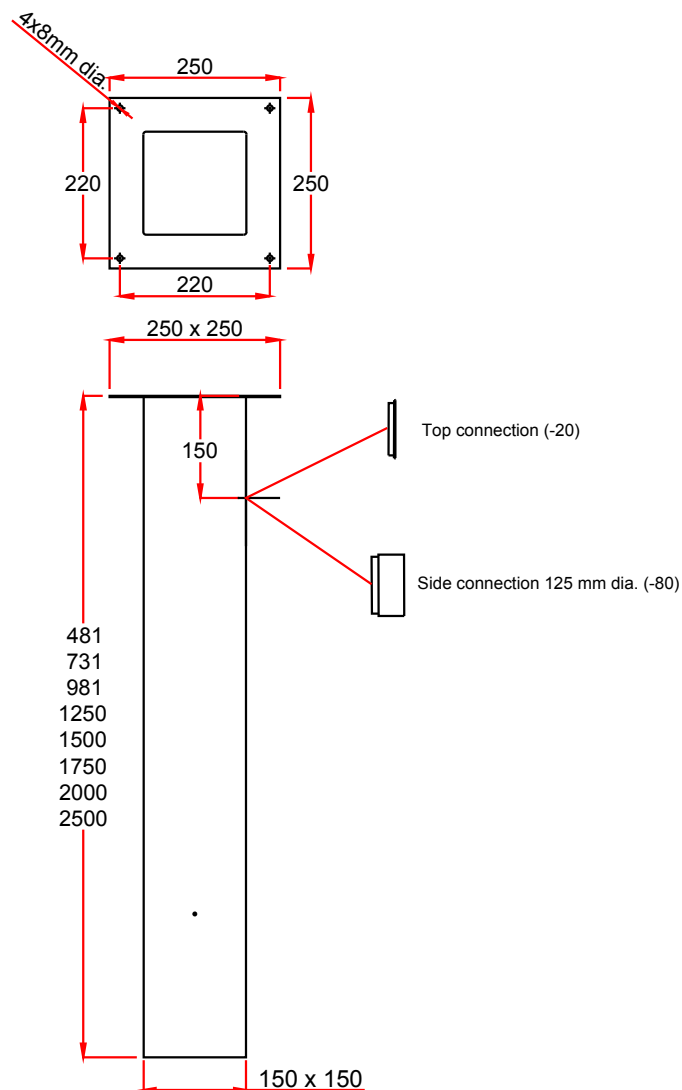



System 100 – Chemical resistant (PP)

- Reducer to connect extraction arm and ventilating duct
- Reduces from Ø125 – Ø100
- Made of polypropylene (PP)
- Colour: white



Drawing

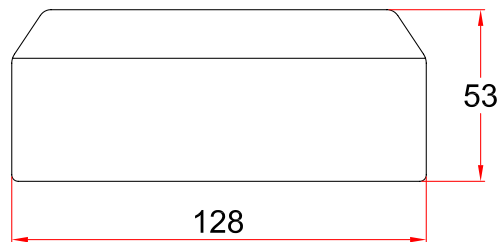



System 100 – Chemical resistant (PP)

- Cover flange to mount on false ceiling.
Hides the carrying of the ceiling column through the false ceiling
- Dimensions: 250 x 250 mm
- Material: polystyrene
- Fasten with glue or small screws
- Colour: white

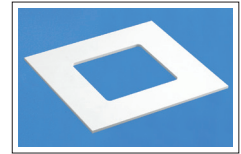

Drawing

For this product there is no drawing

Support bracket 2-100-5



System 100 – Chemical resistant (PP)

- For extra support of long ceiling columns when mounted to ceiling racks or with wires to the deck
- Made of steel with a polyester powder-coating on all surfaces
- Colour: white
- Dimensions: 250 x 250 mm



Drawing

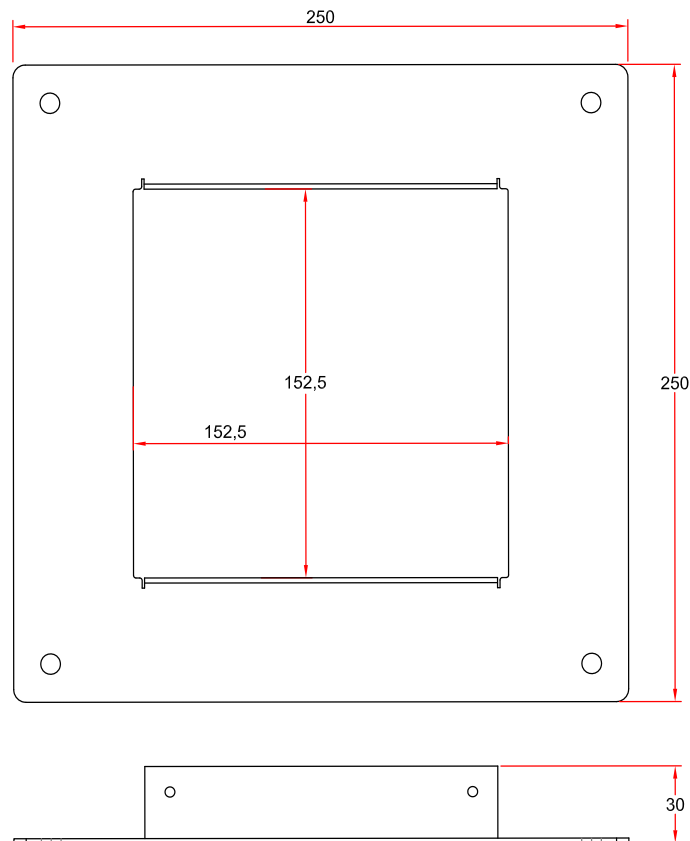



System 100 – Chemical resistant (PP)

- Protective netting to be placed in the hood
- Protects against extraction of foreign objects
- Polypropylene (PP)
- Colour: white



Drawing

