

## Exhaust Extraction

# Channel Duct - Type 25 in extruded aluminum

The Geovent Channel Duct, type 25, is for the extraction of exhaust gas and welding fumes, etc. With up to 48 m duct, the Channel Duct ensures a large working area to the operator, because then he is not dependent on fixed extraction areas, since the trolley may be moved/slid to the required area. The duct may be equipped with up to six trolleys in total. At test stands with up to six trolleys in total. At test stands with linear flow and in medium sized and large garages, the Channel Duct is utilised optimally.

### Easy operation:

The hose trolley is equipped with 6 smoothly rolling nylon wheels, ensuring easy movement of the trolley. Furthermore, the nuisance of having heavy, rolled-out hoses on the floor is avoided. The Channel Duct is available with a substantial variety of accessories, facilitating the daily work for the operator: Electrical, wireless forward and return transport, compressed air nozzles for automatic dismounting of the exhaust, etc.

### Easy installation:

We have made great efforts to ensure the easy installation of our Channel Duct with accessories, meaning that the Duct may be installed very quickly, thus saving money for the erecting engineer.

We shall be pleased to help with the dimensioning.



Channel Duct

### Cross section of channel duct

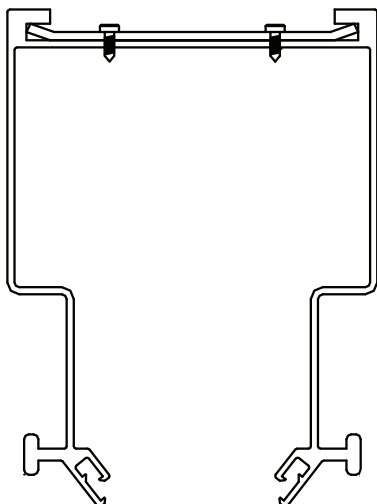

Pressure drop

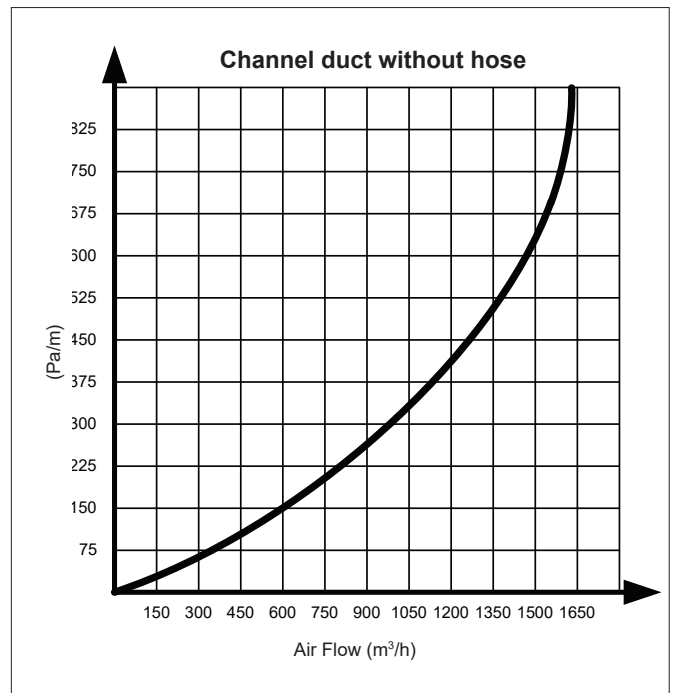
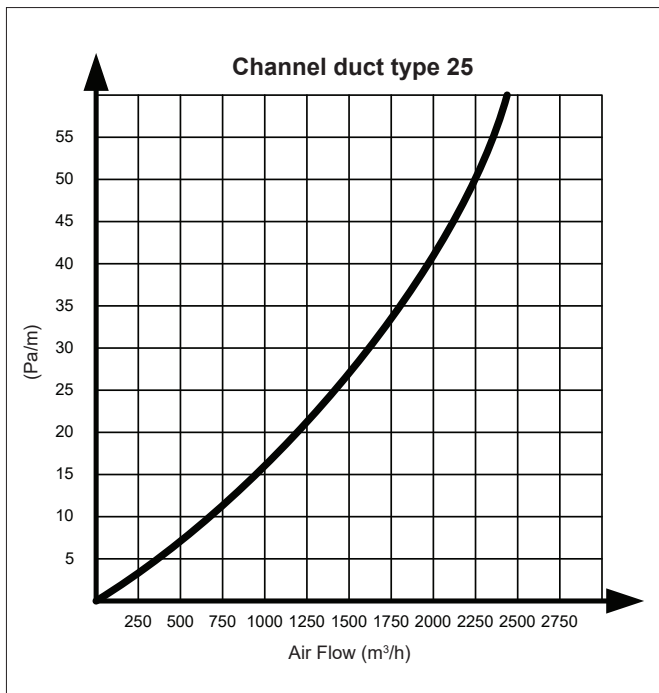
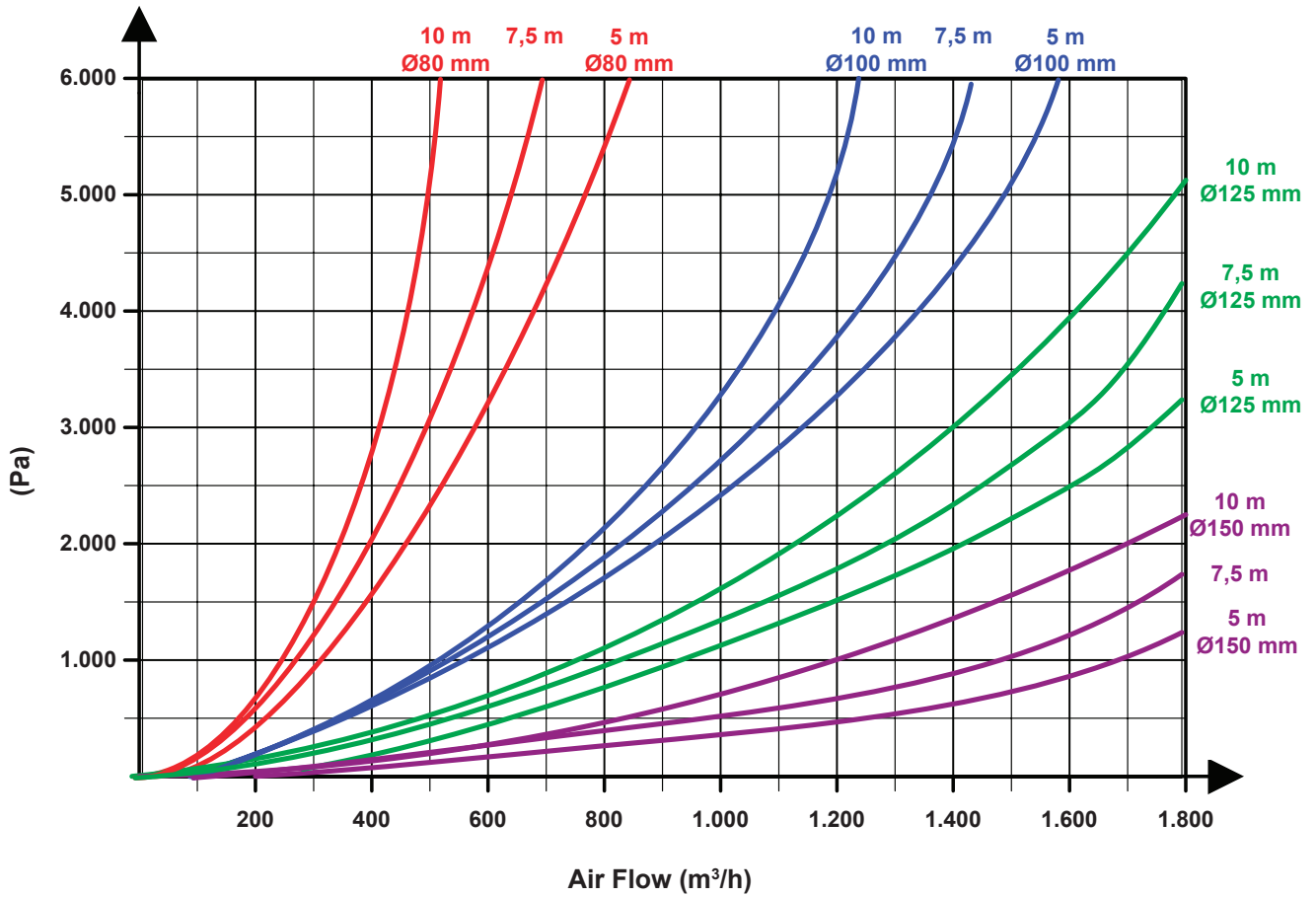

Channel Duct - Type 25 in extruded aluminum

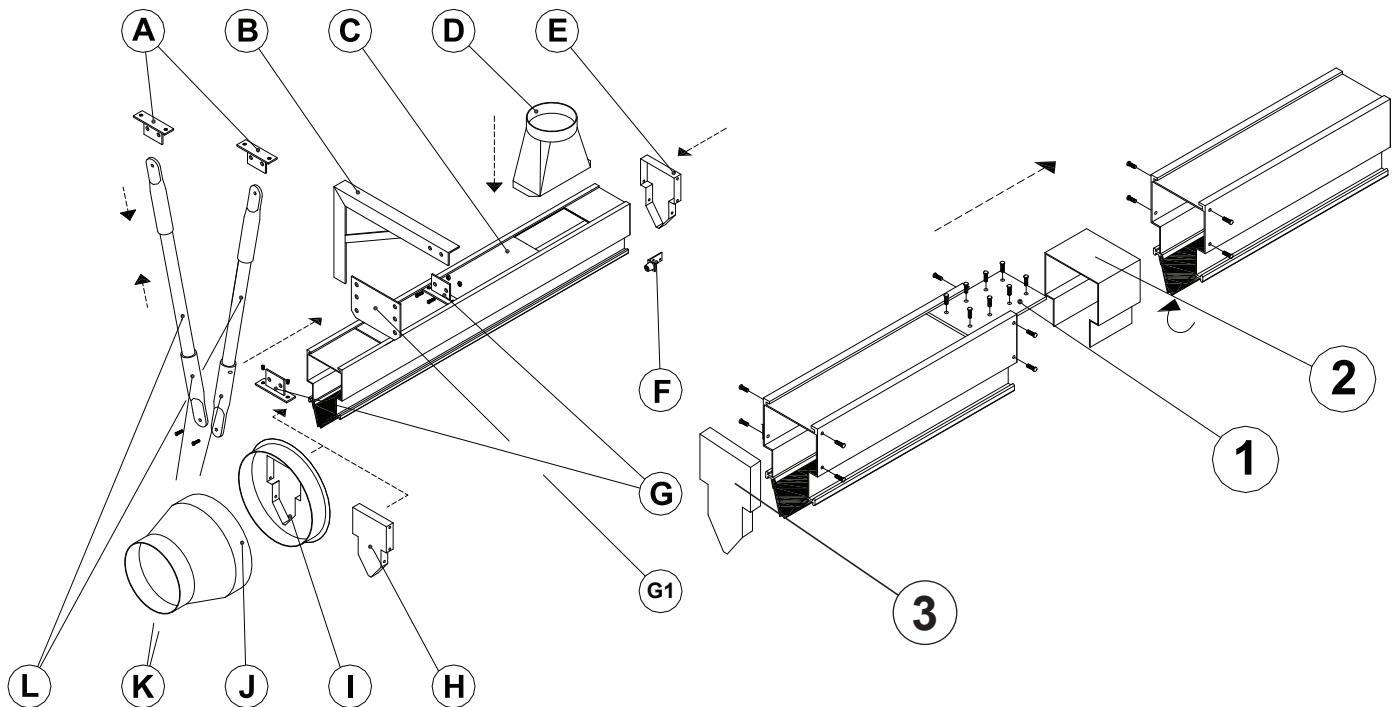

Ordering table for Channel Duct

Pos.	Art. No.	Description
C	07-400	Channel Duct, type 25 in extruded aluminum with heat-resistant neoprene rubber lips
L2	07-401	Channel connecting link, made of galvanised steel plate, for the connection of two lengths of Channel Duct
-	07-401A	
-	07-402	A assembly parts, misc. Accessories for the installation of the channel (1 set is necessary per duct length)
E/H	07-403	End cover, type 25, in galvanised steel
F	07-477	End stop for trolley
-	07-478	Spring stop for trolley
I	07-406	End transition piece, nipple $\varnothing 250$ mm, end of channel Duct to round duct.
J	56-064	Reduction, galvanised, coupling $\varnothing 250$ mm / nipple $\varnothing 160$ mm
K	56-065	Reduction, galvanised, coupling $\varnothing 250$ mm / nipple $\varnothing 200$ mm
D	07-408	Transition for top installation, nipple $\varnothing 160$ mm, from top of Channel Duct to round duct
D	07-409	Transition for top installation, nipple $\varnothing 200$ mm, from top of Channel Duct to round duct
-	04-411	Trolley, type 25, of epoxy enamelled steel, without damper, complete with 6 smoothly rolling nylon wheels and $\varnothing 160$ mm nipple connection.

Channel Duct, type 25 in extruded aluminum. The Channel Duct is supplied in lengths of 2,4 and 6 m



Channel Duct - Type 25 in extruded aluminum

#### Ordering table for Channel Duct

Pos.	Art. no	Model
G	07-656	Suspension bracket, type 60, in galvanised steel. Used both for mounting in the ceiling and on the wall (one required per 2-4 m duct). To be replaced by 07-655, suspension bracket, type 160, when mounted on the side of a concrete beam
K	07-422	Coupling bracket for spacer pipe (set of two), galvanised. Two sets required per point of fixation.
L	07-424	Spacer pipe 3/8", galvanised for 07-422 coupling bracket (required number = 4 x eight from duct to ceiling)
A	07-662	Rocking bracket for ceiling installation. Two brackets required per point of fixation
G1	07-655	Suspension bracket, type 160, galvanised plate for installation on the side of a concrete beam. Three installation on heights (07-456 suspension bracket, type 60 is not required when using this type of bracket.

The Geovent Channel Duct is suitable for ceiling or wall installation or on the side of a concrete beam. Geovent has developed a set of various brackets, facilitating the installation of the Channel Duct. The Duct should be fixed every 2-4 m.

#### Hose suspension bracket parts for Channel Duct

Pos.	Art. no.	Model
-	56-042	Reduction MF160/NP80
-	56-043	Reduction MF160/NP100
-	56-044	Reduction MF160/NP125
-	56-045	Reduction MF160/NP150
-	56-060	Adapter for mounting WING/COMPACT arm on trolley 25
-	07-710	Multi-hose suspension WGS (hook) on neoprene rubber/galvanised steel. For sizes ø76 – ø150 mm.
-	07-421	Wire WGS with ting, 3 m wire and assembly kit for the installation on damper set (N) and hose suspension (T)
-	07-712	Multi - hose suspension on LWS in neoprene rubber/galvanised steel. For hose sizes ø76 – ø152 mm. Used in connection with spring balancers (Z)

## Description of channel duct

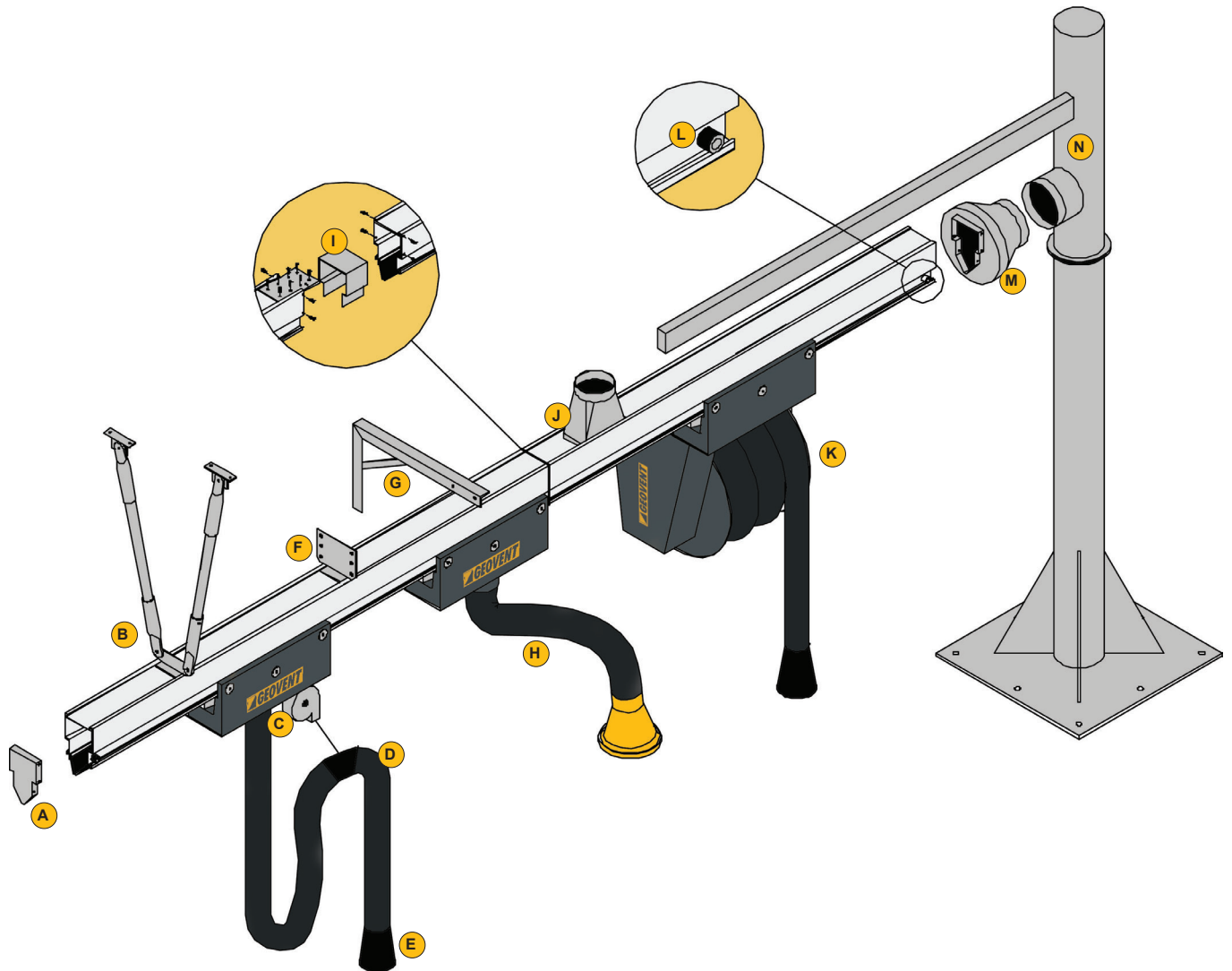

- A: End cover
- B: Ceiling bracket
- C: Balancer
- D: Hose mount LWS
- E: Rubber Nozzle
- F: Suspension Bracket type 160
- G: Wall mount
- H: Extraction Arm  
(WING/COMPACT)
- I: Connection
- J: Outlet Flange, top
- K: Hose Reel with Nozzle
- L: End stop
- M: Channel reduction, end
- N: Pivotable arm 180° or 360°



Channel Duct - Type 25 in extruded aluminum

### Accessories

We have a lot of standard products, but also a lot of special products

- For automation there are wireless automation
- Springbalance can be mounted at the time or later
- Hose and nozzles for special need, it is possible to order

Contact Geovent for more information

### Examples for special solutions

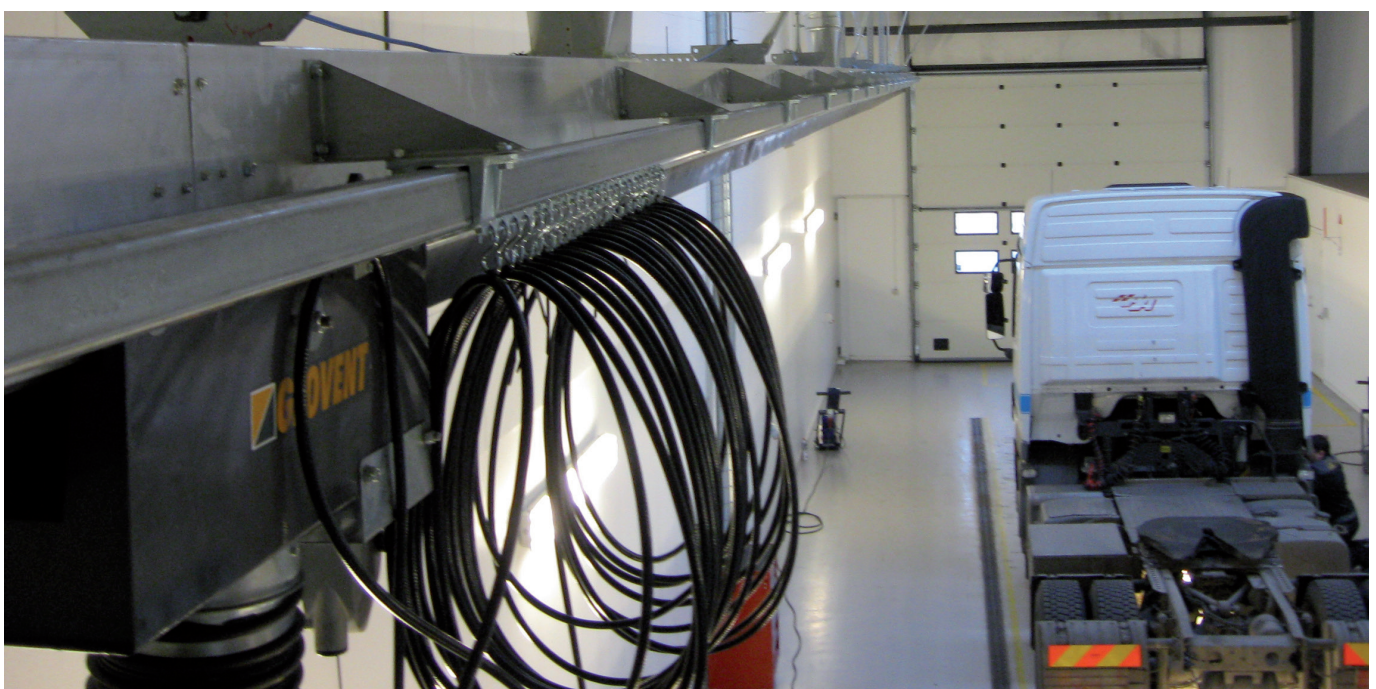



Channel Duct - Type 25 in extruded aluminum

Here are some pictures

