

FUMEX®

REXH RZEXH

Local extractor for explosive environments. Safe equipment when handling explosive gases and dust



Ex
R EXH

Fumex extractor R EXH and RZ EXH are built on a solid construction with external arm support for use in ATEX environments.

Fumex R EXH and RZ EXH is available in Ø100, 125, 160 and 200 mm hose dimension according to requirements.

R EXH and RZ EXH are constructed with:

- Structure, brackets and conical hood in stainless steel SIS2348 (316L)
- Flexible conductive PU hose $R < 10^9 \Omega$
- Gas spring in stainless steel that balances the arms weight.

Fumex R EXH and RZ EXH meet the requirements of the ATEX Directive 94/9 / EC category 2 for gases and dust.

Fumex R EXH and RZ EXH comes with wall bracket as standard. Ceiling brackets are available as accessories.

The Fumex range also includes fans, accessories, automatic control gear and filters for local extractors

LOCAL EXTRACTORS
Pure advantages

ATEX compliant - Local extractor from FUMEX

The standard for quality and safety for explosion protected equipment is called ATEX.

FUMEX local extractors are a safe choice within the pharmaceutical and food industries, as well as in workshop and laboratory environments.



Local extractor R EXH

Lengths 1.5, 2, 3 and 4 m

All parts effectively earthed.

Wall bracket and arm in stainless steel.

Consistently stainless steel components for harsh environments.

Hose, ATEX-classified R<10⁹Ω. Antistatic hose in PU
External arm support in stainless steel

Conical hood in stainless steel.

Local extractor RZ EXH

Lengths 4.5 and 6.5 m

An option with a longer reach.

All parts effectively earthed.

Wall bracket and arm in stainless steel.

Consistently stainless steel components for harsh environments.

Hose, ATEX-classified R<10⁹Ω. Antistatic hose in PU

External arm support in stainless steel

Conical hood in stainless steel.



TIX EXH

Adapted for ceiling mounting of R EXH, RZ EXH-arms. In stainless steel.
Standard lengths 500, 1000 and 1500 mm.



TIX 180 EXH

Adapted for ceiling mounting of R EXH, RZ EXH-arms with an additional link facilitates 180° flexibility left and right. In stainless steel.
Standard lengths 500, 1000 and 1500 mm.



TIZ EXH

Adapted for ceiling mounting of RZ EXH-arms up to 6.5 m. In stainless steel.
Standard lengths 500, 1000 and 1500 mm.

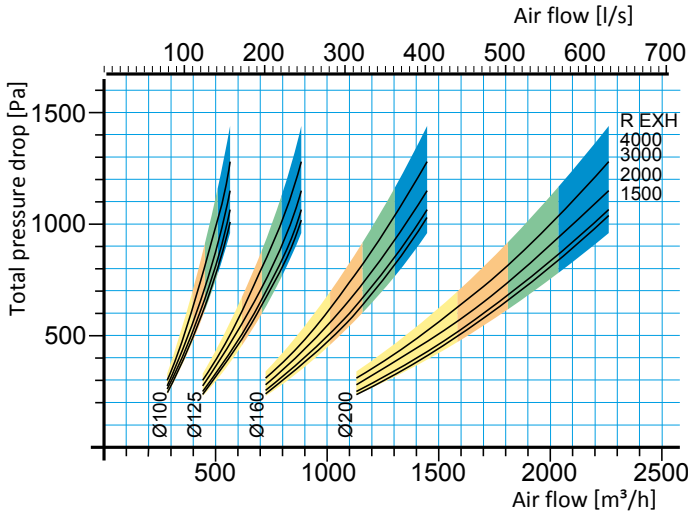

The black line shows the pressure drop for the arm when in the same position as in the design above. The area in the diagram shows the pressure drop at normal use. The field's tints show air velocity in the extractor according to below.

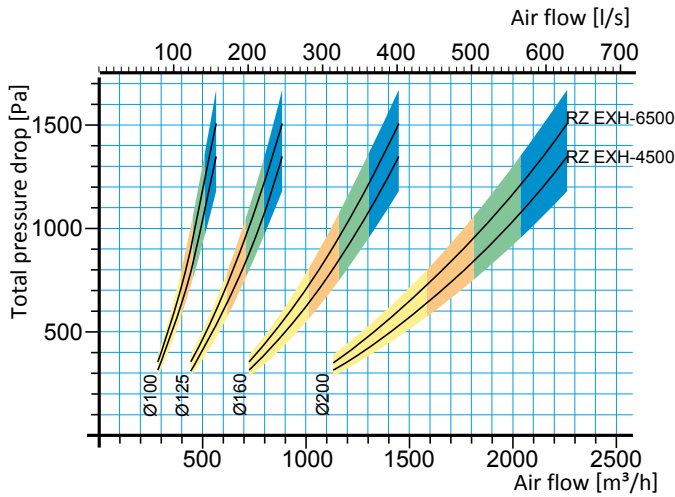

FACTS ABOUT ATEX

Zone classification

Potentially explosive areas or premises are classed in zones according to how often an explosive atmosphere occurs and how long it lasts. The individual in charge of the operation is responsible for the risk area being classified. Classification must be carried out by persons who are knowledgeable about the properties of the flammable goods, the process as well as the equipment. Classification can take place in consultation with safety- and electrical engineers, and also process technicians.

Zone 0 and zone 20

Areas where an explosive atmosphere is present continuously, for long periods or frequently.

Zone 1 and zone 21

Areas where an explosive atmosphere is likely to occur in normal operation.

Zone 2 and zone 22

Areas where an explosive atmosphere is not likely to occur in normal operation, but, if it does occur, will only be for a short duration.

Marking of ATEX products.

Local extractor from FUMEX is marked according to the plate below.

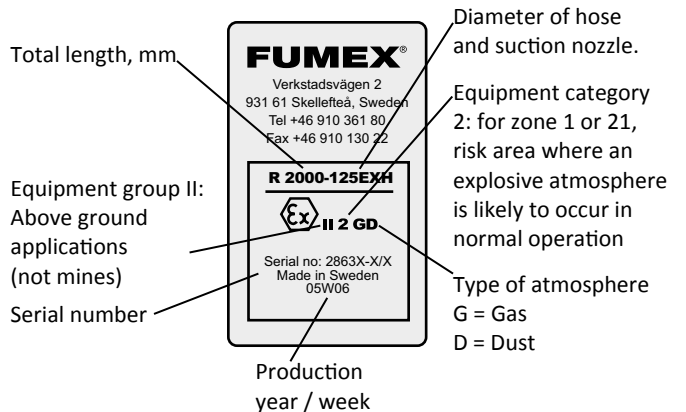

1500, 2000, 3000 & 4000 / 4500 & 6500

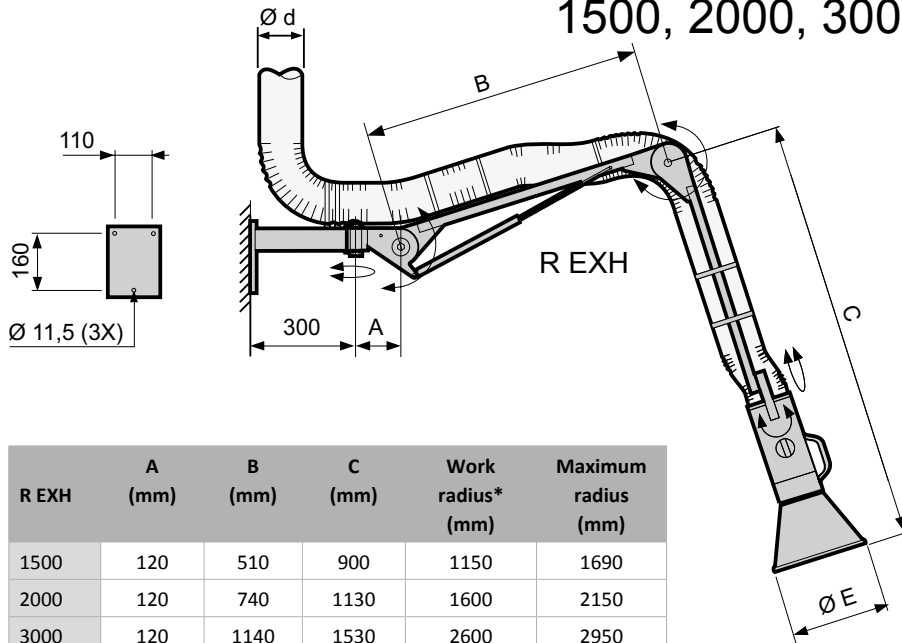

R EXH	A (mm)	B (mm)	C (mm)	Work radius* (mm)	Maximum radius (mm)
1500	120	510	900	1150	1690
2000	120	740	1130	1600	2150
3000	120	1140	1530	2600	2950
4000	1100	1140	1590	3600	3930

Ø d (mm)	Ø E (mm)
100	250
125	250
160	300
200	350

* Recommended mounting height of 2.0 m and a working height of 750 mm.

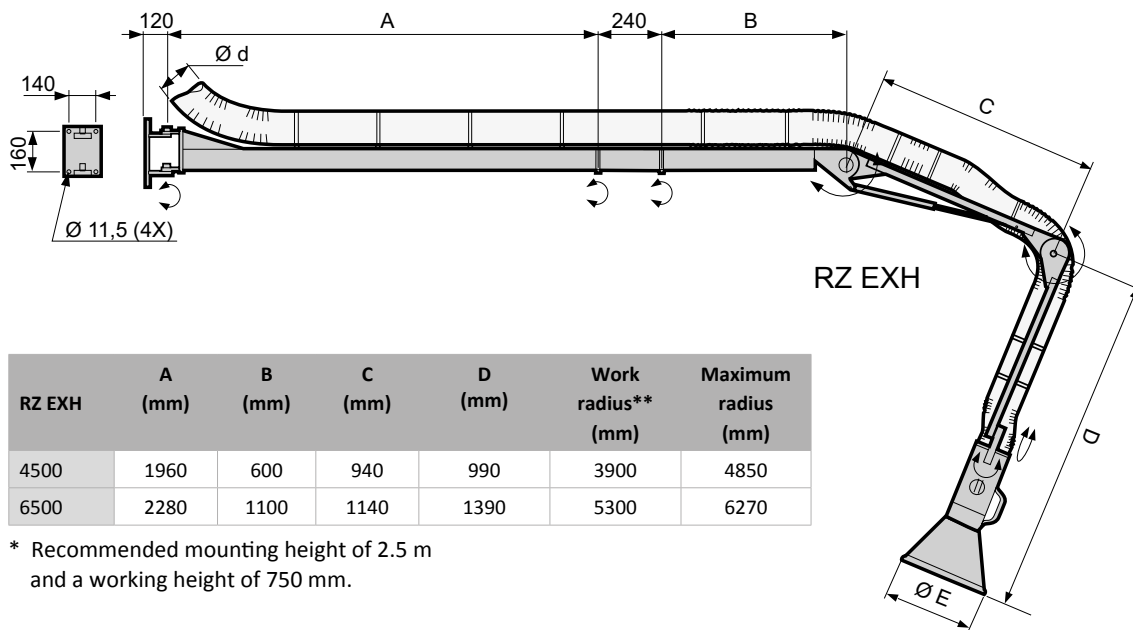

RZ EXH	A (mm)	B (mm)	C (mm)	D (mm)	Work radius** (mm)	Maximum radius (mm)
4500	1960	600	940	990	3900	4850
6500	2280	1100	1140	1390	5300	6270

Ø d (mm)	Ø E (mm)
100	250
125	250
160	300
200	350

* Recommended mounting height of 2.5 m and a working height of 750 mm.

Technical data

Data ATEX

Equipment group.....	II
Equipment category.....	2
Zone, gas.....	1
Zone, dust.....	21
Surrounding temperature...	0 – 60 °C
Hose dimensions.....	Ø 100, 125, 160, 200mm

Material

Structure

R EXH/RZ EXH..... Stainless steel, SS EN 2343

Hose..... Antistatic PU, R<10⁹Ω

Suction nozzle

R EXH/ RZ EXH..... Stainless steel SS EN 2348

Delivery

The arm is assembled mounted and tested. Every arm has a unique manufacturing number.

Tillverkning

Manufactured in accordance with relevant sections of the following standards or regulatory documents: EN 1127-1:1997, EN 13463-1:2001, CENELEC report TR50404, according to the terms in the ATEX directive 94/9/EC.

FUMEX®

Brevo B.V. - Dokwerkerstraat 3 - 2984 BJ
Ridderkerk - 0180-417344 - info@brevo.nl